

Recessed LED downlight

Recessed LED downlight one for one replacement for traditional 1x26W compact fluorescent downlights. Consistent light output with no shadowing. High efficacy, up to 80% energy saving compared with fluorescent light sources. Ceiling cutout \varnothing 150mm - identical to traditional products. AMY VARIO LED can be installed into a wide range of ceiling types of 2-20mm thickness. THD<25%. Switchable colour temperature: choose between warm white (3000K) and neutral white (3500K) and cold white (4000K) to suit application use. Photobiological Risk Group RG0. LED driver suitable for use with leading and trailing-edge dimmer switches. Plug&Play with "Just Emergency E3 KIT" for 3h emergency operation. Body: steel, white finish (RAL 9003). Diffuser: polycarbonate, weight: 0.39 kg.

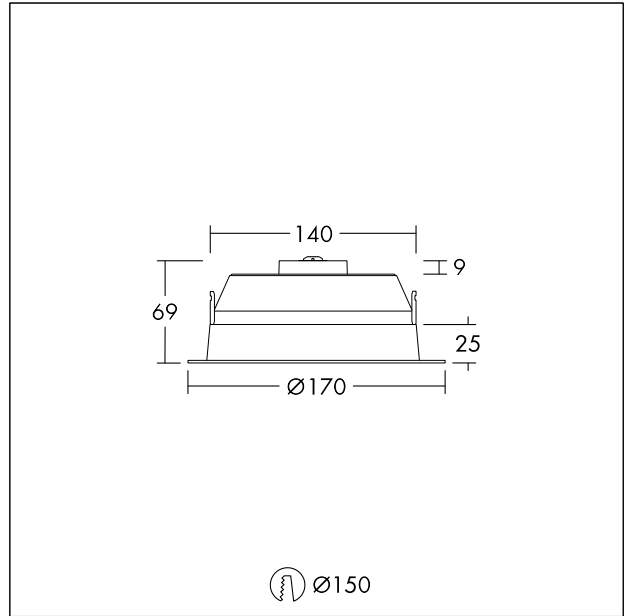

TE_AMYVARIO_F_160.jpg



TE_AMYVARIO_M_160.wmf

Light Distribution

STD - standard

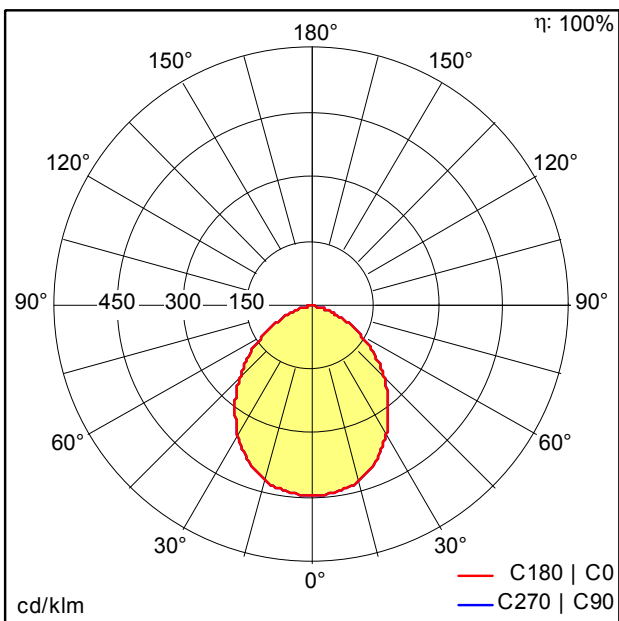

AMY_VARIO_150_LED_DL_1500_840.idt

- Light Source: LED
- Luminaire luminous flux*: 1500 lm
- Total emergency luminous flux: 352 lm
- Luminaire efficacy*: 100 lm/W
- Colour Rendering Index min.: 80
- Correlated colour temperature*: 3000-4000 Kelvin
- Chromaticity tolerance (initial MacAdam): 5
- Rated median useful life*: L80 50000h at 25°C
- Ballast: 1x LED_Con
- Luminaire input power*: 15 W Power factor = 0.9
- Dimming: PCDCG dimmable to 10%
- Maintenance category: D - Enclosed IP2X
- Total harmonic distortion (THD): 25.00 %

This product contains a light source of energy efficiency class E.

All values marked with an * are rated values. Luminous flux and connected electrical load are subject to an initial tolerance of +/- 10%. Unless stated otherwise, the values apply to an ambient temperature of 25°C.